

JP Enterprises, Inc. *Performance Tactical Gear*



Owner's Manual for
SCR-11 • CTR-02 • LRP-07
PSC-11 • JP-15
Rifles and Upper Assemblies

version 05.23.11



READ ALL THE WARNINGS
AND INSTRUCTIONS IN THIS
MANUAL BEFORE OPERATING
THIS RIFLE.

RIFLE INFORMATION

Model _____

Serial Number _____

Rifle Description

Scope

Serial Number _____

Model _____

Accessories

*We at JP Enterprises, Inc. want to thank you for making the right choice and purchasing the best self-loading rifle available. Your satisfaction is very important to us. Therefore, we've endeavored to provide you with all the information you need to make productive and safe use of your rifle. This manual covers many important safety and technical topics relating to rifle ownership, but for certain subjects, we've found the textual medium too restrictive. For this reason, we've recommend that you review segments of the JP informational DVD *GasGunBasics*[™] for more information on certain auxiliary subjects mentioned throughout this manual. If you want to get maximum satisfaction and performance out of your JP rifle, it really is necessary for you to make the time commitment to read this manual and watch the video. Together, the two include a wealth of information and instruction that, if reviewed and implemented, can save you, the owner, a good deal of time and trouble throughout the life of the rifle.*

*Sincerely,
John Paul*

Limitation of Liability

Goods are sold by us with the express and specific understanding that JP Enterprises, Inc. shall not be responsible in any manner whatsoever for physical injury (including hearing loss or eye damage resulting from failure to take adequate precautions while shooting) or property damage resulting in whole or in part from criminal or negligent discharge; unsafe, improper use or careless handling by the user; unauthorized modifications; defective, improper, reloaded, hand-loaded, or non-standard ammunition or improper caliber usage; corrosion, abuse or neglect; or other influences beyond our direct and immediate control. Retail purchase of this rifle implies consent to these terms.

Three-Year Limited Warranty

This JP firearm is warranted to the original retail customer for three years from the date of purchase against defects in the material and workmanship. This covers all parts and labor as well as replacement at our discretion.

Transportation to and from our repair facilities, government fees, damage caused by failure to perform normal maintenance, damage due to excessive pressure or nonstandard ammunition, reloaded ammunition, any unauthorized repair or modification, misuse, abuse or alteration of the product is not covered by this warranty. Sales outside the United States are also not covered by this warranty.

Any implied warranties, including the implied warranties of merchantability and fitness for a particular purpose, are limited to one year from the date of purchase. Consequential or incidental damages and/or expenses, or any other expenses, are not covered by this warranty.

To obtain warranty service contact JP Enterprises, Inc. for shipping instructions.

Problems/Returns

While we endeavor to provide you with products in the best possible condition, sometimes problems occur. If there is a problem with our product or damage incurred in shipping, call us immediately for assistance. Remember that it is illegal to ship a firearm and ammunition in the same package. Ammunition must be shipped separately.

TABLE OF CONTENTS

SAFETY	4
DOs and DON'Ts of Rifle Use	4
Safety Features	7
RIFLE OVERVIEW	8
Rifle Function	8
JP Rifle Components	9
RIFLE USE	14
Dry Fire Practice	14
Ammo Selection	15
Magazine Selection	16
Loading, Firing and Unloading	16
Break-In Procedure	19
Choosing Optics	20
Adjusting Optics	20
Accuracy	20
DISASSEMBLY AND REASSEMBLY	21
Clearing the Rifle	21
Disassembly	23
Reassembly	27
CLEANING AND MAINTENANCE	31
Cleaning the Rifle	31
Inspection of Critical Parts	35
Replacement of Parts	36
Cleaning the Crown	36
Cleaning the Magazine	37
Special Cleaning Considerations	37
Storage	39
TROUBLESHOOTING	39

In this manual, the correct standard terminology has been utilized to refer to self-loading rifles of the Gene Stoner design. The small-frame version of this rifle—usually chambered to fire the 5.56x45 NATO or the .223 Remington round—will be referred to as the M15 for the civilian semi-auto version or the M16 for the select-fire military/police version. The large-frame version of the Stoner design—usually chambered in the 7.62x51 NATO or the .308 Winchester family of cartridges—will be referred to as the AR-10 variant.

SAFETY

Firearm ownership, like scuba diving or rock climbing, is an endeavor that demands personal responsibility. If you cannot take responsibility for your actions, firearm ownership is not for you. If carelessly or improperly handled or stored, this or any other firearm has the potential to cause great damage to property and severe injury or death to people and animals. If you are unfamiliar or uncomfortable with the usage of firearms, seek additional training and/or education through qualified instructors or organizations such as local gun clubs or the National Rifle Association. Before using your new rifle, read through the entirety of this manual beginning with this safety section to ensure that you are intimately familiar with its use and operation.

The DOs and DON'Ts of Firearm Ownership

These are the four commandments of gun safety. Memorize them and instruct all others in your family or shooting group to make sure that these rules are understood completely and followed explicitly.

1. *Treat all firearms as if they were loaded.*
2. *Do not sweep anyone or anything with the muzzle of your firearm that you are not willing to destroy.*
3. *Keep your finger out of the trigger guard until you are ready to fire.*
4. *Be sure of your backstop.*

Most all of the safety precautions in this section originate with these rules, and if you take nothing else away from this manual, make sure that you remember and follow these. Due to the importance of this material, though, we will expand further.

DO handle your firearm at all times as if it were loaded. Unless you are presently looking at the empty chamber, the firearm should be treated as a loaded weapon. The only firearm that you can say is unloaded with certainty is the one that you have just checked and which is still in sight. Once it is out of your sight, you can no longer say with absolute certainty that it is unloaded.

DO keep the safety selector lever in the “SAFE” position whenever you are not immediately ready to fire.

DO practice stance, aim, rhythm and breathing with your unloaded firearm before practicing with live ammo, and practice thoroughly with your rifle at the range before going hunting or attempting other shooting sports.

DO instruct children and other members of your household to respect firearms and to follow safety procedures regarding guns, even if they do not shoot them regularly or even at all. If you intend to teach children or family members to shoot, have them trained by a qualified instructor and supervise them while they operate firearms.

DO appoint a knowledgeable and responsible individual to manage the safety of large shooting groups making use of a range facility. You should defer to, and insist that others defer to, that individual's authority for everyone's sake. Additionally, you should ensure that you are personally qualified to fill this role if necessary.

DO clean and maintain your firearm responsibly. (See the **CLEANING AND MAINTENANCE** section of this manual.)

DO use only high-quality, good-condition ammunition in your firearms. (See the **Ammo Selection** section of this manual) Be aware that the ammunition requirements for your JP rifle may be different from certain other M15- or AR-10-type rifles.

DO seek medical advice regarding medication you take to determine if it will interfere with your ability to operate a firearm safely.

DO wear ear protection while you or anyone in your vicinity is operating a firearm. Additionally, insist that those around you wear ear protection while in the presence of discharging firearms. Not doing so could result in temporary or permanent loss of hearing.

DO wear eye protection—and require others to do the same—while firearms are being discharged. Flying particles or debris could cause eye damage to the operator or those around him or her.

DO keep clear of the firearm's ejection port as spent cartridge casings are expelled from the weapon at high speeds and temperatures capable of injuring or burning. Ensure that other observers do likewise. In particular, be aware that ejected casings may bounce off walls and other objects in some range situations and enter open-topped clothing causing severe burns. It is always a good idea to wear a cap with a brim while shooting to help deflect spent cases from the face and eyes.

DON'T point the muzzle of the firearm at anything you are not willing to destroy. This includes times when the firearm is unloaded and when it is being inspected and cleared. It is never a good idea to handle a firearm in a situation with people standing all around you. Always clear a safe zone for the muzzle. In the field, rifles should be carried with the muzzle pointing up or down, never at the horizontal.

DON'T trust that the firearm is unloaded merely because you are told so. Visually check it yourself.

DON'T insert your finger into the trigger guard until you are ready to shoot. This decreases the likelihood of an accidental discharge. If you handle firearms long enough, it is a statistical certainty that eventually you will have an accidental discharge. Knowing this should give you added incentive to exercise safe muzzle and trigger control.

DON'T shoot your rifle unless the bore, muzzle, chamber and action are clear of obstruction. Verify that there is no such obstruction only after ensuring that the firearm is unloaded.

DON'T leave your firearm exposed and unattended, whether loaded or not.

DON'T transport your firearm while it is loaded, whether just around the range or over longer distances.

DON'T carry a loaded firearm in such a way that you are not fully in control of the direction of the muzzle. Always carry a rifle muzzle up or muzzle down.

DON'T inflict or allow blunt impact to your firearm, such as dropping it onto a hard surface. The firing mechanism could be triggered causing the gun to fire while not under control. Additionally, components of the firearm may be damaged reducing the overall safety of the weapon. If such damage occurs, have your firearm examined by a qualified gunsmith before further use.

DON'T allow others to operate your firearm unless they are informed and comfortable with the use of such weapons. Make sure that they follow all the preceding and following rules, because while someone is using your firearm, you are responsible. It is always a good idea to allow a new shooter to dry-fire your rifle before loading live ammo.

DON'T discharge your firearm unless you are certain of your backstop's integrity. Be certain that no bullets will pass through the backstop to potentially cause damage or injury. In the field, only fire at game or targets if you are sure that a miss or a bullet passing through the target will be contained in the visible area behind the intended target.

DON'T attempt to alter or modify your firearm, especially if attempting to change the trigger pull weight of the weapon. Alterations to certain components or their relationships with each other can affect the overall safety of the mechanism and potentially result in unexpected discharge, damage or malfunction.

DON'T drink alcohol or use drugs or other substances that may impair brain function, judgment, physical dexterity or vision while operating a firearm.

DON'T use your firearm in poorly ventilated areas. Continued use could result in accumulation of lead and other toxic particulate matter in the air that could be injurious to health.

DON'T use your firearm if water is in the barrel. If your firearm is submerged, exposed to heavy rain or otherwise drenched, dry the water and clean the weapon before attempting to use it.

DON'T shoot at a hard surface like a rock or at a liquid surface like open water. Doing so may cause the bullet to ricochet and change trajectory unexpectedly.

DON'T discharge your weapon in the presence of an animal that has not been trained to accept the noise. The animal may panic and cause damage, injury and general confusion.

DON'T allow or partake in "horseplay" with a firearm under any circumstances.

Safety Features

Safety Selector

The selector lever, located on the left of the lower receiver, has two positions, "FIRE" and "SAFE." When set to "FIRE," the rifle will fire a single shot each time the trigger is squeezed. When set to "SAFE," a cam bears upon the rear portion of the trigger, blocking the sear surface of the trigger and preventing the hammer from releasing. Check the function of the safety from time to time with the rifle unloaded. Verify that the rifle is clear, cycle the action using the charging handle to cock the hammer, place the safety selector in the "SAFE" position and squeeze the trigger. The trigger should have no perceptible movement, and the hammer should not fall.



Safe



Fire

Disconnecter

The disconnecter, which is part of the firing mechanism, prevents the firearm from firing in the fully automatic mode. As the hammer is cocked after each shot by a rearward movement of the bolt carrier, the disconnecter engages the hammer to hold it rearward until the trigger is released. When the trigger is released, retention of the hammer passes from the disconnecter to the sear surface of the trigger, which is ready for the next shot.

Firing Pin Collar

The bolt carrier assembly, located within the upper receiver, is designed to prevent the firing pin from striking a cartridge until the bolt is locked to the barrel. If the firing pin should be struck by the hammer before the bolt is locked to the barrel, the firing pin could not move forward through the face of the bolt, because the firing pin is held positively rearward by the collar on the firing pin, which bears against the rear surface of the carrier.

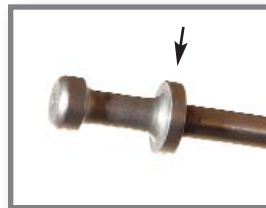

RIFLE OVERVIEW

This section is intended to give you an informative look at the function of an M15- or AR-10- type rifle in general, as well as the specific components and features that make a JP rifle unique.

Rifle Function

Gas-operated, self-loading rifles like the M15 and AR-10 have a semi-automatic action that functions as follows:

With the action cocked, chamber loaded and safety selector lever set to "FIRE," the trigger can be depressed in order to discharge the weapon. Upon activating the trigger mechanism, the trigger rotates, disengaging the trigger sear surface from the hammer. The hammer spring drives the hammer forward to strike the firing pin, which in turn strikes the primer in the base of the cartridge. Once struck, the primer composition is ignited, which then ignites the main powder charge in the cartridge. High-pressure gases push the bullet down the barrel where rifling grooves impart stabilizing spin to the bullet.

As the bullet passes the gas port of the barrel, which is located underneath the JP Gas Block, gas is tapped off and directed through the gas tube running underneath the hand guard and into the bolt carrier chamber driving the carrier rearward. As the bolt carrier moves to the rear, the cam track in its upper surface acts upon the cam pin causing it, and the bolt through which it passes, to rotate until the locking lugs of the bolt are no longer in engagement with the lugs of the barrel extension. The bolt is now unlocked and is carried rearward by the bolt carrier. The extractor extracts the spent cartridge case and holds it against the face of the bolt until the ejector throws the spent case through the ejection port.

The bolt and carrier continue rearward, compressing the action spring and returning the hammer to the cocked position until the buffer assembly strikes the bottom of the receiver extension. The action spring then forces the bolt and carrier forward so that the face of the bolt strips the next round of ammunition from the magazine and thrusts it into the chamber. At the same time, the extractor snaps into the groove of the cartridge case, and the bolt locks into the barrel. The hammer

is now held rearward by the disconnecter, and when the trigger is released, the disconnecter is rotated back releasing the hammer. However, before the disconnecter hook actually releases the hammer, the trigger sear surface has rotated in front of the hammer notch so that the hammer is held on the trigger sear surface ready for another shot. Thus, as a semi-automatic firearm, the rifle is automatically and immediately loaded and ready to fire again after each shot until the magazine is empty.

JP Rifle Components

What follows is a listing and explanation of the components unique to a JP rifle that contribute to its superior function. Many of these entries include maintenance instructions and should be considered supplementary to the **CLEANING AND MAINTENANCE** section of this manual. Also, be aware that our rifle configurations are numerous, and so not all rifles will be equipped with each of the following components.

JP Recoil Eliminator/Compensator

If your rifle is equipped with the JP Recoil Eliminator or the JP Compensator, be aware of the following. The purpose for a recoil-eliminating device on the muzzle is to lower the sight recovery time of the shooter by reducing the movement of the rifle as each shot is fired.

It does this by harnessing otherwise wasted kinetic energy of the

muzzle gases and directing them against baffle surfaces. The inside forward surfaces of the baffles will show some erosion over time, but this will not affect performance until the exit hole is actually burned through completely. The life expectancy of the barrel may exceed the life of the muzzle brake, and eventually the brake may need to be replaced. Typically, muzzle brakes used on rifles fired in a semi-automatic mode will last about 10,000 to 12,000 rounds.



Muzzle brakes by their very nature redirect high-pressure gases and can blow dirt or other materials present in the shooting area back towards the shooters or bystanders, especially at indoor ranges with enclosed shooting booths. Noise may also be increased to the shooter and definitely to bystanders. **Eye protection and earplugs or earmuffs are required equipment when shooting or observing firearms with muzzle brakes or compensators. At indoor ranges, a combination of both earplugs and earmuffs is strongly recommended.** There are many good products on the market to fill this need, such as stereoscopic hearing muffs that protect while still allowing you to hear, even while using earplugs. JP Enterprises, Inc. is not responsible for hearing loss resulting from exposure to gunfire.

JP Fire Control System

JP rifles feature the most refined single-stage fire control mechanism available. Before you use your rifle, check to make sure it is clear, and then dry-fire it several times to become accustomed to the drastically improved feel and lighter weight of the trigger. If you allow others to fire your rifle, have them do the same to reduce the likelihood of an accidental discharge.

Every performance gain will have some corresponding cost in reliability or durability. Although we have designed this system to give what we feel is the optimum compromise between performance, reliability and durability, it is a highly refined system that requires the parts to maintain much more critical tolerance relationships than the standard M15 or AR-10 fire control system. After thousands of rounds, these relationships may change due to normal wear, and the system may need readjustment or replacement parts.



It is important that you lubricate the high-load surfaces—such as the disconnecter engagement surface and the sear/hammer notch surfaces—for maximum parts life. We recommend using RyDol® Boron Nitride Grease or a similar high film strength lubricant designed for such applications.

JP Adjustable Gas System

The purpose of our adjustable gas block is to allow you to control the pressure delivered to the operating system and thereby optimize the bolt velocity, which will result in a smoother shooting more reliable rifle, especially if you already have a JP Recoil Eliminator. The ability to adjust the operating pressure also improves the overall reliability and longevity of the operating system. Most rifles cycle faster than necessary, and the resulting “bolt slamming” effect is a noticeable part of the recoil impulse.

The gas system is preset during the test fire procedure by JP. It is set high for this break-in with a bias towards reliability using domestic 55-grain FMJ test loads with good port pressure. You may choose to use it at this factory setting, and if your rifle is used for law enforcement or military purposes, we recommend leaving it at this setting so as not to compromise reliability. If your rifle is primarily for varmint hunting or some non-critical use, and you want to get maximum effect by fine-tuning the operating pressure at the price of an occasional stove pipe, that is a possibility, and it does make a noticeable difference.



The gas block adjusts from the right side, and hex keys are provided in the accessory kit for this. Before attempting this adjustment, make sure you are comfortable with the basic operation of the rifle described later in this manual. When you decide to tune the gas system for a particular load, begin by turning the gas adjustment screw in all the way to close it.

Then, back it out about two full turns. Load one round of the ammunition into a reliable magazine and fire. Ideally, the bolt should hold open after the last round of the magazine is fired. Once this happens, the gas block is set. This is not likely to happen without some adjustment, though, so if the bolt does not stay open, it is still short-stroking, and the valve should be opened about another half turn. Continue to back out the screw until the bolt locks open consistently on the last round. Test again with one round in the magazine. In situations where reliability is critical, we recommend giving it another quarter to a half turn open.

Remember, if you change ammo, port pressure may vary, and the rifle should be tested again with any ammunition that you intend to use in actual competition or critical application. If you must use untried ammo, back out the valve a full turn to ensure full cycling. You may also wish to use blue Loctite® 242 to secure the valve screw.

If you want to convert to manual operation to avoid losing brass or peppering the shooter next to you in a shoulder-to-shoulder situation like a formal shooting range, that is another option with this system. However, for any application where reliability is essential, tune the gas system on the conservative side, leaving the rifle a bit over-gassed.

Most gas block models feature a mil-standard 1913 Picatinny quick-detach point to accommodate any compatible accessory you may wish to use, such as quick-detach front sights, flash lights, lasers or electronic sights.

JP Tactical Operating System

The JP Tactical Operating System consists of a full-mass buffer system and a full-mass 416 stainless carrier. It is designed to maximize the operational window of the rifle and allow for highest possible reliability under adverse conditions. The 416 stainless carrier does not require a hardcoat chrome process in the bore and allows for the use of a special roller burnishing finish process in the bore that results in closer tolerance control and a lower overall friction between the bolt/carrier relationship. Lower friction results in more energy reserved to overcome adverse functional conditions. The Tactical Operating System is recommended for all applications where reliability is essential.



JP Low Mass Operating System

The JP Low Mass Operating System consists of a special low mass carrier and buffer system. We have designed this to be a “race gun” option only, and it should not be used on rifles intended for military or police duty or for personal defense. Like most performance features, it represents a compromise that yields a significantly improved and controllable recoil impulse at the expense of overall reliability. When used in the non-combat, relatively controlled environment of recreational or competitive shooting, we feel that it is an acceptable compromise and will not affect reliability with reloaded ammunition tailored to, or factory ammunition proven in, a well-maintained rifle. However, the Low Mass Operating System does result in a slightly reduced “operational window.” In other words, the system requires ammunition yielding a port pressure within a certain range, and the rifle must be better maintained and lubricated than one with a full-mass tactical operating system.

Lubricate the low mass carrier every 200 to 300 rounds with Firepower FP-10™ or some other high-quality, low-viscosity gun oil by placing a couple of drops on the four bearing surfaces of the carrier. Also, place one drop on the cam pin, one in the exhaust ports on the right side of the carrier and one on the locking lugs



of the bolt, spreading it around with your finger. If you happen to be shooting in a very dusty environment, more frequent lubrication may be necessary to keep dirt from forming a retarding sludge. If the action feels sluggish, it likely requires cleaning and lubrication. The low mass system does not have the kinetic energy storage capacity of the full mass operating system and will not tolerate a lot of impediment. Do not use Kellube M12 or any high-viscosity oil on this part, as they have too much retarding effect.

After some use, you will see small marks from hammer impacts on the bottom of the carrier as it is reset during live fire. This is normal wear and is cosmetic in nature only. It will not affect the lifespan of the parts. Eventually, you will notice that the black finish is wearing off on the top bearing surfaces next to the carrier key. This is also normal wear and should cause no alarm.

If you intend to shoot off the magazine, which is a common technique at some tactical format matches, you must be sure that your magazines do not interfere with the carrier. Test them as follows: disassemble the magazine, and with only the empty housing inserted and locked into place and the full weight of the rifle resting on the magazine tube, cycle the action and verify that there is no interference between the bolt carrier and the feed lips of the magazine.

Most problems with the JP Low Mass Operating System are caused by carbon buildup in the bore of the carrier. A couple of drops of oil in the exhaust ports followed by cycling the empty rifle in and out of battery several times is usually enough to scrub this fouling off the carrier walls and keep the rifle in the operational window. At a match, it's a good idea to lubricate between every rifle stage just as an added measure of caution. The test for carbon buildup in the bore of the carrier is as follows: pull the bolt/carrier back (on an empty chamber) and allow it to go forward slowly with the charging handle. It should close fully with the action spring tension alone. If it must be assisted, or allowed to drop from the fully open position, the carrier is fouled.

JP Modular Hand Guard

The JP modular hand guard system is an extremely versatile component that can integrate numerous Picatinny rail sections to allow for the addition of accessory items such as lighting, vertical grips, secondary sight systems and co-witnessed infrared night vision systems at any position on the hand guard tube. The hand guard comes standard with three quick-detach studs for any type of sling or bipod interface and can accommodate more if desired.



For mounting at the 12:00 position of the hand guard, we offer carbine-, mid-, and full-length rails in addition to a front sight specific two-inch rail section. Two-inch and four-inch rail sections are then available for mounting on any other position on the hand guard tube. These two-inch and four-inch rail sections are attached using a backer plate that is placed inside the hand guard tube and rides in one of the slots providing stable yet versatile mounting for your accessories.



JP Tension Pin

Unless you request to have the tension pin installed, your rifle will be shipped with the standard push pin for ease of break-in cleaning and service. The tension pin is available as an upgrade option and can be installed at any time. It results in a tensioned hard fit between the upper and lower receivers, which will enhance accuracy at the expense of bit more effort in the takedown procedure. We do not recommend using the tension pin in a law enforcement rifle, home defense rifle or field use rifle, as it makes emergency takedown to clear a fouled trigger group impossible.

To install the tension pin, remove the butt stock from your lower assembly and be careful not to lose the takedown pin detente plunger and spring, which will protrude from the back of the lower receiver. Remove the plunger, spring and takedown pin and store them for future use. Unscrew the cross bolt of the tension pin and apply a small amount of some non-permanent thread locking agent such as Loctite® 242 to the inside of the threaded section of the wedge to prevent the device from loosening while firing. Insert the JP Tension Pin from the left side of the receiver with the slotted end first by using the hex key provided to hold it. Position the slotted end with the orange reference dot at the 12:00 position on the right side of the receiver to ensure proper orientation. See diagram A. Note the position of the center floating compression wedge piece and make sure it is orientated back and down (towards the web between the grip and stock) when inserting the pin. See diagram B.

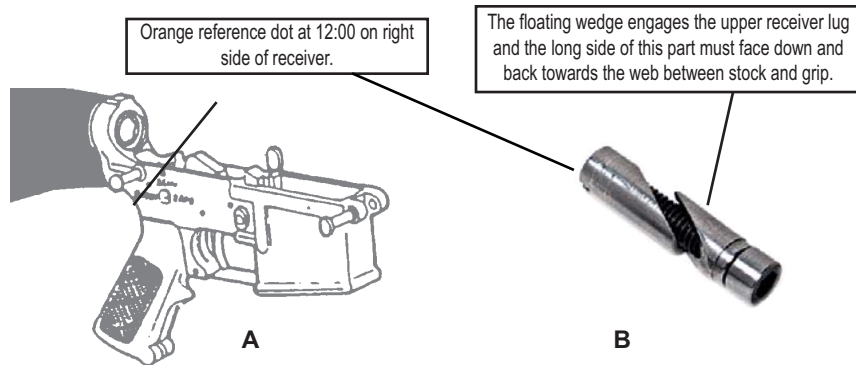

Now, using the hex key, tension the pin, and if it is properly installed, the upper assembly will be pulled back and down on the lower with no remaining play. It may be necessary to use an appropriate screwdriver on the slotted end while tensioning with the key to prevent it from slipping. Do not over tension the pin as this will eventually cause the floating wedge piece to “mushroom,” making it difficult to remove and insert the pin even in its de-tensioned condition. If this happens, clean up the edges of the wedge pieces with a small file.

RIFLE USE

Before heading out to the range for the first time, there are several issues discussed in this section that contribute to optimal and enjoyable usage of your new rifle.

Dry Fire Practice

Dry fire practice is a tool used by all pro-level shooters to enhance their skills. It doesn't cost anything, can be done at home if safety precautions are taken and will make your live-fire practice much more productive and efficient. As mentioned in the section on safety, you should practice your stance, aim, trigger control and breathing with your unloaded rifle to accustom yourself to the weight of the weapon and how to move with it. It is, however, imperative that you conduct such practice in a very controlled situation with a secure backstop and no live ammo or loaded magazines available. You will obviously want to clear your rifle for these sessions, but conduct them as if your weapon were loaded to ingrain the safe handling of the rifle in your mind if for no other reason. If you choose to perform such practice in your home, such as in your basement, do so only in a secure environment that will unquestionably prevent a fired round from escaping the secured portion of the building uncontrolled or impacting volatile targets like gas lines. For such practices, make sure to use a backstop adequate to obstruct and retain the expended rounds of the caliber you are using and to situate such a backstop against a ballistically secure surface.

Ammo Selection

There is a huge assortment of ammunition and components on the market for M15 and AR-10 rifles at present. A manually operated rifle will fire anything that the action can force into the chamber. A self-loading rifle, however, must have ammunition that fits in a rather narrow window of size and pressure constraints. In other words, it must be a drop fit in the chamber without the projectile interfering with the lands in the throat area. It must also have adequate port pressure to cycle the action and not too much chamber pressure to impede extraction or cause any of the more serious manifestations of excess chamber pressure.

There are a number of factory loads we have encountered that do not have adequate port pressure and may cause short stroking, resulting in failure to eject, stove pipes or failure to pick up the next round in the magazine. Other rounds have excessive pressure and cause extraction failures. Some steel-cased ammo made overseas has a varnish coating on the case that will cause chamber fouling and eventual extraction failure. There is also now ammunition with plastic cases available that we have found to have very low port pressure.

Every rifle will have its own personality, and ammo that happens to function in one may not function in another. When participating in a match, make sure you have an adequate supply of proven ammo for your rifle to avoid having to buy some untried ammo at the event.

As a rule, use only new high-quality ammunition or remanufactured ammunition from companies with a reputation for quality. In particular, stay away from foreign-manufactured ammo, as it may not meet SAAMI specifications. Although reliable function may be achieved with NATO specification ammunition or commercial military equivalent ammunition loaded with typical 55-grain full metal jackets, the full accuracy potential of your JP rifle will only be realized with high-grade ammunition—often referred to as match grade ammunition—not generic military loads.

Pay attention to the caliber and chamber type on your rifle and choose your ammunition accordingly. An M15-type JP rifle is chambered using the .223 Wylde chamber specification, which will allow the use of ammo with the commercial .223 Remington designation or the 5.56 NATO designation.

The LRP-07 rifles are chambered in either 7.62 NATO or .260 Remington. The former will accommodate ammunition of either the .308 Winchester commercial designation or the 7.62 NATO designation. The latter is a SAAMI commercial chamber only, and ammunition must meet SAAMI specifications to function safely.

If you decide to reload your own ammunition, you must watch the pertinent sections of the [GasGunBasics™](#) DVD to understand how to load functional, safe and accurate ammunition for the M15-type rifle. The video addresses the 5.56/.223 cartridge specifically but the loading techniques apply to handloading for any self-loading rifle such as an AR-10 or the JP LRP-07. Do not assume that if you load for a manually operated rifle that your ammo will function in a self-loading rifle.

Remember that in any case, ammunition used in a self-loading rifle must meet more stringent dimensional specifications and produce a pressure curve in a narrower range than ammunition that may be suitable for a manually operated action such as a bolt action. Nearly all function and accuracy problems with quality M15-type rifles are ammunition related. In particular, avoid using the following types of ammunition:

- Israeli ammunition
- Korean ammunition
- PMP
- South African surplus
- Any ammunition with lacquer-coated cases
- Steel-cased ammunition
- Ammunition with steel-jacketed projectiles
- Ammunition with steel-cored projectiles

Magazine Selection

Like the ammunition you choose, the magazine can also have a dramatic effect on the function of your rifle. It is important to note that the magazines for the M15/16-type rifles were originally designed to be disposable in combat, and little consideration was given to the long-term durability of mil-spec magazines. Currently, there are a number of higher quality aftermarket magazines that have been designed specifically for long-term durability and improved function, such as the Magpul™ composite magazines, which we recommend. Magazines are relatively cheap, and you will likely own a number of them. Become acquainted with each one, perhaps going so far as to number them so you can remember their individual personalities. Some may be more reliable than others, and if a particular magazine produces a certain feed malfunction or fails to lock back on the last round, service or replace it. The least reliable magazines are the reduced capacity 5- or 10-round magazines.

Loading, Firing and Unloading

If you haven't already, read the above advisory regarding ammunition selection for your rifle and select your ammo accordingly. While loading, make sure to keep the rifle pointed in a safe direction, and do not touch the trigger. The following steps will walk you through the complete sequence of preparing your rifle, firing it and reloading it to fire again. If you are using your rifle for the first time, make sure to read the Break-In Procedure section below.

1. With the shorter front end of the magazine facing forward, place a cartridge between the lips of the magazine with the bullet forward. Press the cartridge down until it is held by the magazine feed lips. Place the next round on top of the previous cartridge and repeat until capacity is reached.

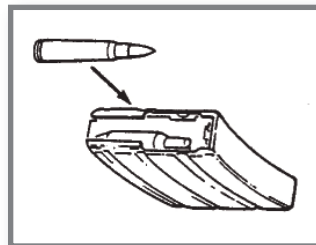

2. On the rifle, pull the charging handle rearward and press in on the lower part of the bolt catch to cock the hammer and leave the bolt carrier latched open.



3. Return the charging handle forward until it locks and then remove your finger from the bolt catch.
4. Place the safety selector lever in the "SAFE" position. Note that if the hammer is not cocked, the lever cannot be turned towards "SAFE."

5. After verifying that the chamber is clear and the bore is not blocked, insert the magazine, with the bullets pointed forward, into the magazine well and push upward until it is caught and locked in place by the magazine catch.



6. While keeping fingers clear of the ejection port, depress the upper part of the bolt catch, which will release the bolt and carrier to move forward and feed the top round of the magazine into the chamber. Be aware that there is the potential for a slam fire when releasing the bolt to charge the rifle. It is very important that the muzzle is pointed down range or in a safe direction when charging the rifle in case this occurs. Do not point the rifle up in the air when releasing the bolt. The bullet must be safely absorbed by the backstop or the ground in the event of a slam fire when charging.



7. Place the safety selector lever in the "FIRE" position.

The rifle is now loaded and ready to fire. Before continuing, verify the safety of the shooting environment, including the quality of the backstop and the absence of people, animals or property in the line of fire.

8. Grasp the pistol grip firmly with one hand and steady the rifle by grasping the hand guard with the other. Seat the buttstock comfortably but snugly against your shoulder. Your sights or optic should be mounted to allow for a firm, but not too tight cheek weld with the stock.
9. Placing your finger in the trigger guard, take aim with the rifle and gradually squeeze the trigger until the first round is discharged. In order to maintain a steady grip on the weapon, avoid jerking the trigger and removing your finger from the trigger between shots. Continue firing until the magazine is empty or you wish to stop. For more information on trigger control, review the pertinent section of *GasGunBasics™*.

10. Place the safety selector lever in the "SAFE" position.

11. While pressing the magazine catch, pull the magazine out of the magazine well.



12. Pull the charging handle to the rear while pushing in the lower portion of the bolt catch. This will eject a remaining round that may be in the chamber and lock the action in the open position. If the last round in the magazine had been fired while the magazine was in place, the bolt and carrier should have been locked to the rear by the last round lock back function of the magazine follower and bolt catch.



13. When the magazine is removed and the chamber is empty, push the top portion of the bolt catch to allow the bolt and carrier to return forward.
14. Remove any remaining live rounds from the magazine by sliding them forward and out.
15. Collect live ammunition for safe storage and spent cartridge cases for disposal.

After shooting your rifle, always remove the magazine and verify that the weapon is unloaded completely before casing and transporting it. Do not store the rifle with the magazine inserted in the rifle, as this is an indicator of a loaded weapon. If you do keep loaded weapons for duty purposes or home defense, a magazine inserted in any weapon should be an immediate and clear indication that the weapon is ready to fire.

Break-In Procedure

Although modern barrel manufacturing techniques result in vastly improved bore finishes and minimize the need for elaborate break-in procedures, we still recommend a minor break-in procedure to maximize accuracy potential.



Your rifle has been test-fired for function, but the barrel has not been truly broken in. We recommend the following procedure to obtain optimum accuracy potential from your barrel. At your first use, fire 10 to 20 rounds and then clean the bore using solvent and J-B® bore compound, which will have a mild lapping effect in your new barrel. Follow this by mopping the bore using a clean cotton patch with a little more solvent. Repeat this procedure every 20 rounds for the first 60 rounds, then again after the next 300 rounds. The J-B® compound is not necessary for every cleaning, but will also serve as an excellent copper fouling remover when necessary.

Choosing Optics

Most JP rifles will be used with optical sights as the primary sighting system. Choose your optics with the intended application in mind. If you expect to shoot tight groups on paper or engage long-range targets of some sort, don't use a dot sight with zero magnification. Dot sights cannot yield the accuracy potential out of any rifle. On the other hand, if you intend to engage moving targets at close range, the dot sight may be ideal while a 6x20 target scope is completely useless. This subject is covered in *GasGunBasics™* in detail. Most people are interested in the accuracy potential of their rifles. Therefore, everyone should have at least one long-range parallax-correctable scope on hand for shooting groups or load development.

Adjusting Optics

Even the most expensive scope is nearly useless if it is not set up and properly adjusted for the task-at-hand. Refer to *GasGunBasics™* for a detailed discussion of setting up your optics. A detailed discussion of optics selection, application, setup and adjustment is included in the DVD for your benefit.

Accuracy

When speaking about accuracy, we refer to it in terms of minutes of angle or MOA. One MOA is just a bit over an inch at 100 yards, two inches at 200 yards and so on. Accuracy functions as a cone of dispersion that a particular rifle is capable of delivering with a certain load by a certain shooter under certain conditions. Obviously, the cone of dispersion will increase in MOA under adverse conditions such as cross winds.

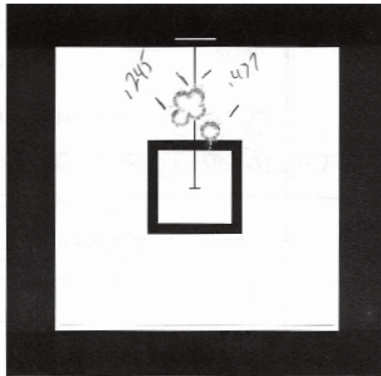

Many things affect accuracy, the most obvious being the ammunition and the shooter's ability to shoot accurately. Poor trigger control technique on the M15- or AR-10-type rifle is a common cause of poor accuracy. Many bolt gun shooters accustomed to feathering off the trigger of a bolt gun with the tip of their finger need to develop a completely new trigger control technique with a self-loading rifle.

Parallax error in optical sights is another common source of shot dispersion that is often overlooked by the shooter, as are mounting systems that are not stable. Temperature, humidity, wind and lighting can also greatly affect accuracy.

The level of accuracy you can expect from your JP rifle depends on many things. It is unrealistic to say that every rifle will shoot ¼ MOA groups, although that level of accuracy is obtainable with

the M15-type rifle, and we have produced test groups as tight as .172" at 100 yards. You must have the right elements assembled in the correct order to achieve a certain level of accuracy. The *GasGunBasics™* DVD goes into detail on this subject.

With a high-quality parallax correctable scope properly mounted, match-grade ammo and good bench technique, sub-MOA accuracy should be possible at 100 yards for a skilled shooter. However, if you decide to use something like a non-magnifying dot sight and military grade ammunition, expect accuracy in the 1½ to 3 MOA range.

Atmospheric conditions also have a great effect on accuracy. Although it may be great practical experience to shoot in adverse conditions with high wind and mirage, do not expect to achieve the full accuracy potential of the rifle under those conditions.

Most accuracy testing with rifles is performed at 100 yards. Obviously, the further the target, the more the atmospheric conditions, the consistency of the ammunition and the shooter's ability come into play. Shooting a one MOA group at 100 yards is one thing; achieving one MOA accuracy at 400 yards is about an order of magnitude more difficult. The important thing is to have realistic expectations for a given rifle setup with a given ammunition under a given set of circumstances.

DISASSEMBLY AND REASSEMBLY

Between outings with your rifle, a thorough disassembly of your rifle will occasionally be required for maintenance. The following steps will walk you through the disassembly and reassembly process and help to familiarize you with the internal components of the rifle. Be aware that these processes vary slightly for side-charging rifles (SCR-11, LRP-07, PSC-11). Where needed, alternate instructions for side-charging rifles appear in green boxes below. Because the PSC-11 features both styles of charging systems, these instruction supplement (rather than replace) those for the standard top-charging rifles.

Before you begin disassembly, make sure to clear the rifle as described below.

Clearing the Rifle

1. Place the safety selector lever in the "SAFE" position. If the rifle is not cocked, the lever cannot be turned towards "SAFE."
2. Remove the magazine if not already removed.



3. Pull the charging handle rearward and press the bottom of the bolt catch button until the bolt locks.



4. Return the charging handle to the forward position.

Locking Open the Action on Side-Charge Rifles

Due to the left-side charging system of the SCR-11 and LRP-07, manually locking the rifle action open without a magazine requires one of two different techniques. For the PSC-11, the following techniques are optional since the rifle can also be locked back with the standard charging handle.

Method 1: Hold the rifle with your right hand on the pistol grip and your finger out of the trigger guard. With your left hand, pull the action open all the way to the rear. When the action reaches the end of travel, use the middle finger of your left hand to actuate the bolt catch lever by pressing in at the bottom. With a little practice, this is a very fast manual lock back technique that allows you to retain your shooting/control grip on the weapon.

Method 2: This technique is preferable if you have small hands and can't reach the bolt stop with your middle finger while holding the charge handle to the rear. Begin by securing the rifle buttstock under your right arm. Pull the action open all the way to the rear using the charging handle. Reach underneath the rifle and cup the magazine well with your right hand, and then use the index finger of your right hand to actuate the bolt stop.



5. Visually inspect the receiver and chamber to ensure that no cartridge is present. Remember that just because no round is ejected from the receiver when locking the bolt back does not mean that there is no round in the chamber. There is no substitute for visually inspecting the chamber.

6. Release the bolt by pressing the upper portion of the bolt catch.



Disassembly

Before beginning the "field strip" described in the following steps, take care to lay out the removed components in an organized way as some can easily be misplaced and lost.



1. Press the rear takedown pin in from the left of the lower receiver and pull it out the right side until it comes to a positive stop. The pin cannot be completely removed as it is retained by a detente plunger. Bear in mind it may be necessary to use a punch to remove the takedown pin if the fit between the receivers is tight. If you use a punch and mallet to perform this task, be very gentle, as it is possible to break the detent plunger out of the side of the receiver with excessive force. Such damage is not covered under any warranty and will require the replacement of the lower receiver.

2. Pivot the lower receiver down and away from the upper receiver.

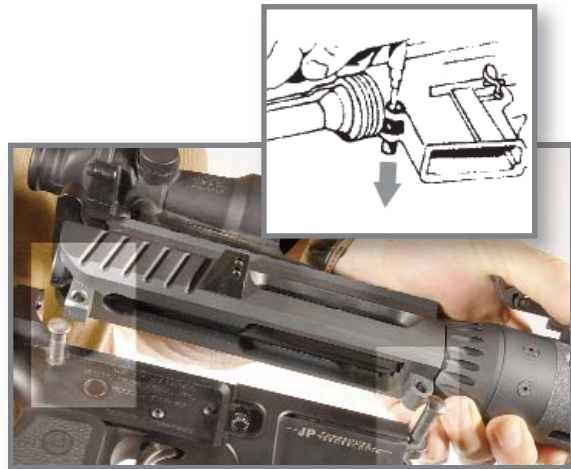

3. Press the front pivot pin in from the left side of the lower receiver, and pull it out the right side until it comes to a positive stop. Again, this pin is retained by a detent plunger and cannot be completely removed.

4. Separate the upper and lower assemblies.

5. On the lower assembly, hold the buffer in its current position to prevent it from ejecting suddenly when the buffer retainer is depressed. Depress the buffer retainer to permit the buffer and spring to move forward. Then, depress the hammer to allow the buffer and spring to be easily removed from the receiver extension.



Removing the buffer and action spring is not necessary for regular maintenance. It need only be removed every 1,000 to 2,000 rounds (or at least once a year) unless there is a specific problem requiring access to it.



6. On the upper assembly, pull the charging handle to the rear and remove the bolt and carrier assembly.

7. Remove the charging handle by pulling it backwards and down out of the upper receiver.

Disassembly of Side-Charging Rifles

The takedown of the side-charging SCR-11, LRP-07 and PSC-11 varies slightly from a standard top-charging rifles. For the SCR-11 and LRP-07, the directions below replace steps 6 and 7 on page 24. For the PSC-11, the disassembly directions below are in addition to steps 6 and 7.

1. Extract the bolt carrier assembly before attending to the charging assembly.



2. Move the charging handle assembly to the rear where there is a takedown notch. With the handle held out, lift the charging handle slider off the receiver rail through the takedown notch.

8. Push the two-pronged end of the firing pin retaining pin into the bolt carrier and remove it from the other side.



Disassembly and Reassembly

9. Tilt the bolt face up and remove the firing pin. Tapping the back of the bolt carrier on a hard surface will help dislodge the firing pin, and it should fall out the rear of the bolt carrier assembly.



10. Push the bolt in towards the carrier until it rotates and comes to a stop. Then, turn the cam pin 90°.

11. Remove the cam pin by lifting it out and away from the bolt and carrier.



12. Pull the bolt forward out of the carrier.



Disassembly and Reassembly

The remaining steps describe removing the extractor. Normal servicing need not include removal of the extractor or ejector from the bolt assembly. These can be left in assembly unless you intend to replace these parts as part of long-term maintenance or are experiencing extraction or ejection failures that may require closer inspection of these parts.

13. With a punch, remove the extractor pin from the bolt assembly.



14. Remove the extractor and spring, but do not remove the spring from the extractor or the ejector retainer pin, which is smaller and located near the front of the bolt.

15. Press the top of the extractor spring rubber tip to test spring functionality.

Unlike many other rifles of this kind, removal of the JP Modular Hand Guard is not necessary for routine cleaning and maintenance. During installation, Loctite® is used to secure the hand guard components, and they should only be removed in order to address a specific gunsmithing concern that necessitates access to that area of the rifle.

Reassembly

1. Reinsert the buffer and spring assembly into the buffer extension tube until the buffer retainer plunger snaps up in front of the buffer to secure it.



2. Reassemble the extractor and spring in the bolt, reinserting the extractor pin.
3. Make sure that the gas rings are staggered as shown below, and insert the complete bolt assembly into bolt carrier.



4. Rotate the bolt so that the ejector pin is in the lower right while looking at the bolt face. Align the cam pin hole with the cam pin slot in the carrier and insert the cam pin. Rotate 90° so that the firing pin hole is in alignment with the firing pin channel in the bolt assembly.

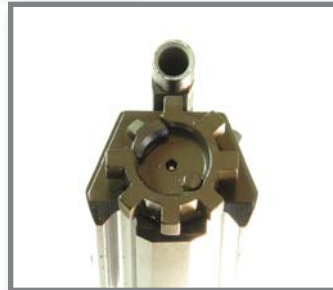

5. Insert the firing pin into the rear of the bolt carrier assembly and press it all the way forward until the skirt rests on the back of the bolt tail stock.

6. Insert the firing pin retainer pin through the back side of the bolt carrier with the split opening vertically. Apply a slight downward pressure on the exposed loop of the pin to guide it through the hole on the opposite side of the bolt carrier.

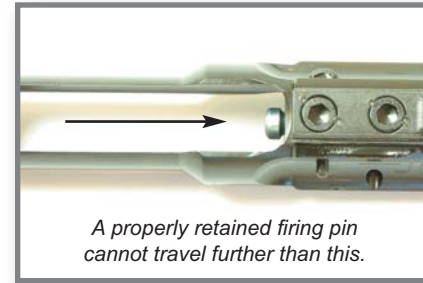

Make sure that the firing pin collar is forward of the pin and that the firing pin anvil is in back of the retainer pin. Test the assembly by rotating the bolt in and out of the carrier and, with the bolt assembly in battery, press the firing pin forward to verify that it protrudes from the front of the bolt face. Tap the back end of the bolt and carrier assembly on a hard surface to verify that the firing pin is properly retained.

Failure to properly assemble the bolt and carrier assembly will cause serious malfunctions at the very least and severe damage to the rifle and possible injury at the worst. In particular, if the cam pin is not installed, the rifle will still fire, but the bolt will not be in the locked position. If this happens, catastrophic destruction of the rifle will occur leading to the possible injury or death of the shooter or bystanders.



Example of catastrophic failure due to cam pin in bolt/carrier assembly.



7. Insert the charging handle assembly into the receiver by locating the tabs over the cutout in the top rear of the upper receiver and pressing the tabs down into the charging handle slot. The charging handle should now slide freely in and out of the upper receiver.

Reassembly of Side-Charging Rifles

To reassemble the upper assembly you will reverse the disassembly process above. The directions below replace (SCR-11, LRP-07) or come in addition to (PSC-11) step 7 on page 29.

Lift the handle away from the charging handle/slider assembly holding it out from the slider. Lower the slider onto the takedown notch of the receiver rail and slide it forward until it comes to a stop in the forward position.

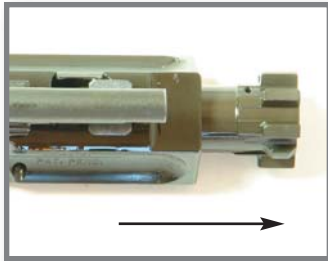

- Pull the bolt assembly into the fully forward position as part of the bolt and carrier assembly and insert the entire assembly into the upper receiver. Note that the carrier key and cam pin must be in alignment with the charging handle slot in the upper receiver to insert it into the receiver. Press the bolt and carrier and charging handle assembly fully forward to the locked in-battery position.

- Place the complete upper assembly on the complete lower assembly and press the rear push pin in first, then the front pivot pin in next to fully capture the upper on the lower. If the pins are too tight to insert with finger pressure, use a plastic or rubber mallet to tap in the pins.



- Check for proper assembly and function by pulling the charging handle to the rear and releasing. Dry-fire the rifle while pointing it in a safe direction and repeat the process, finally locking the action open.

CLEANING AND MAINTENANCE

On your JP rifle, the barrel and carrier are made of the finest 416 stainless steel alloy, which is highly corrosion resistant. In fact, due to the limited use of carbon steel components on a JP rifle, cleaning after every use may not be necessary, and you can even damage a barrel by over-cleaning it. However, if you only shoot very occasionally, you should certainly clean and lubricate the rifle before storage.

If you shoot bullets that are not moly-coated, you should clean the bore of your rifle about every 300 rounds. If you shoot nothing but moly-coated bullets, cleaning is only required every 500 rounds or so. Lubrication is recommended before every use even if you don't clean the rifle. In normal environmental conditions (see below), lubricate your bolt and carrier assembly before every use and the trigger mechanism every 300 rounds with a good sear lubricant.

If you're on a varmint hunt and expect to fire hundreds of rounds in a sitting, lubricate your bolt and carrier assembly at least every 200 to 300 rounds. It is not necessary to take the bolt and carrier out of the rifle to do this; merely place a drop of good gun oil over the exhaust ports of the carrier and work the carrier back and forth a few times to disperse this oil in the bore of the carrier. This will dislodge fouling in the bore of the carrier, and subsequent live fire will blow that oil into the upper receiver further lubricating the bearing surfaces of the carrier. Running the upper receiver wet is the best thing you can do to increase the longevity of your operating system and receiver.

Rifle maintenance can be divided between short-term and long-term procedures. Short-term maintenance includes cleaning the bore and operating system at least every 300 rounds or more depending on the extent and frequency of use and storage periods. Long-term maintenance would include such things as cleaning and lubricating the buffer and action spring, detail stripping of the bolt assembly, cleaning the crown of the rifle, and thoroughly cleaning the fire control cavity and components of the lower receiver. These services may be required after 1,000 to 2,000 rounds. With proper short- and long-term maintenance, your JP rifle will give many years of great service.

Cleaning the Rifle

To perform the cleaning regimen described below, begin by field stripping the rifle as described in above. You will need the following tools and substances:

- Cleaning rod with a tight jag (not the slotted-type jags)
- Cotton flannel patches cut to fit snugly into the bore
- Small toothbrush
- Dental picks
- Good-quality gun oil with low- to medium-viscosity like Firepower FP-10™ (Do not use high-viscosity oils that might be used for handgun applications.)
- Gun cleaning solution (Avoid using carburetor cleaner or any ultra aggressive solvents formulated for other industrial cleaning. Damage from inappropriate solvent use is not covered under warranty.)

- Brass wire bristle bore cleaning brush
- Chamber cleaning brush
- AR-15/AR-10 Chamber mop
- Variable-speed drill (optional)

Cleaning the Upper Assembly

1. Attach the brass wire bristle brush to the cleaning rod and dip the brush in gun cleaning solution. Inserting the brush from the breach end only, thoroughly scrub out the barrel, passing the brush all the way through before reversing motion. If you try to change direction with the brush in the barrel, it will stick. Also, avoid contact between the cleaning rod and the muzzle, as resultant wear will reduce accuracy.

Using a JP Cleaning Rod Guide as a tool to insert into the upper receiver is recommended to prevent the rod from damaging the crown, throat or chamber of the barrel. Damage to the crown, which can also result from inserting the cleaning rod through the muzzle for cleaning, can dramatically affect accuracy and is expensive to remedy.

2. Attach a cotton flannel patch to the end of the cleaning rod. Saturate the patch with bore solvent. Insert it through the rod guide in the chamber and pass the rod and patch through the barrel. Repeat the process with a fresh patch until the last patch comes out clean.
3. Visually inspect the barrel. If it is clean, proceed to step 5. If it remains dirty, continue with step 4.
4. Attach the larger chamber cleaning brush to the cleaning rod, dip the brush in bore cleaning solution and clean the chamber. Use a maximum of five plunge strokes and three full clockwise rotational strokes. You may wish to use a variable speed drill for cleaning the chamber if you're careful. If so, chuck up the last section of rod with the chamber brush installed on the end. Plunge the brush in and out of the chamber several times while running the drill at medium speed. This will remove any chamber fouling in seconds and dislodge debris from the locking lug area of the barrel extension piece. If you have compressed air available, you can use it to blow out the locking lug area at this time, but make sure to wear eye protection while doing so.

If you find your bore still does not come clean, it may be heavily fouled by copper or lead, in which case a product like J-B® bore compound should be used to remedy the buildup. Refer to the instructions on the package.

5. Now, use a chamber mop to remove any remaining solvent from the chamber. Run a final dry patch through the bore to catch any solvent or dirt from the chamber that may have proceeded up the bore.

If you intend to store your rifle for an undetermined or extended period before its next use, now is the time to prep the bore for storage. Lightly moisten a flannel patch with gun oil and pass it once through the barrel to leave a film of oil on the inside surface.

6. After dipping a toothbrush in gun cleaning solution, use it to clean carbon and powder residue from the following areas:
 - Bolt locking lugs
 - Gas rings
 - Firing pin
 - Bolt cam pin
 - Lip of the extractor
 - Opening of the bolt carrier key
 - Interior of the bolt carrier from both front and rear
 - Around the gas tube opening in the upper receiver
7. Use a dental pick to clean the crevices in the bolt face and extractor claw to remove any brass shavings and carbon buildup from the bolt face. A dental pick may also be used to remove hardened fouling not removed by the toothbrush.

When cleaning aluminum surfaces such as the receivers, do not use a wire brush. If cleaning is necessary, you can avoid scratches and wear by using a small toothbrush or flannel patch.

8. Wipe all components clean and dry. Inspect them for excessive wear, corrosion or mechanical damage. See the **Inspection of Critical Parts** section below. If any of these faults are discovered, have them corrected before firing again. If components need to be repaired or replaced, contact JP Enterprises, Inc. or a qualified gunsmith to make arrangements.
9. Lubricate the following parts with gun oil:
 - Ejection port cover latch (if applicable)
 - Ejection port cover spring (if applicable)
 - Action springs and pins
 - Charging handle catch and spring
 - Inside rear of the bolt
 - Mouth of the carrier key
 - Forward assist (if applicable)
 - Bolt carrier bearing ways
 - Gas rings on bolt assembly
 - Cam pin bearing surfaces
10. Using a good sear lube like RyDol® Boron Nitride Grease, lubricate the sear and hammer notch and the hammer/disconnector surfaces. You may use a good lithium grease for this application if nothing else is available.

11. Verify that cotton fibers and brush bristles have not become lodged in any part of the firearm such as the bore and that there is not excess lubricant or solvent remaining.
12. Reassemble the rifle as described above.
13. Remove any gun cleaning solution, oil or fingerprints from the outside surfaces of the firearm. Finger moisture, if left uncleaned, could cause corrosion.

Cleaning the Lower Assembly

Regular cleaning of the lower assembly does not require removal of the fire control components. Because of the fine-tuned relationship between these parts, removal or adjustment of the fire control mechanism should only be performed by JP Enterprises, Inc. or a qualified gunsmith.

1. Remove the buffer and action spring as described in the disassembly instructions.
2. Wipe all lubricant and dirt from the spring and buffer with a clean piece of cloth.
3. Wipe out the buffer extension tube using several large cleaning patches on your cleaning rod or a piece of cloth.
4. Use gun oil or graphite to lubricate the action spring and buffer body, depending on your conditions. Do not use grease on these parts, as it will cause malfunctions in cold conditions.
5. Making sure that you have not left any patch or material in the buffer extension tube, reinstall the buffer and spring.
6. Use a degreasing agent or spray solvent such as Birchwood Casey® Gun Scruber to clean out any debris such as dirt, unburned powder, brass shavings or primer parts from the fire control cavity of the lower assembly. If you have access to compressed air, use it to remove all foreign material from the fire control cavity. Again, make sure to wear eye protection while using compressed air.
7. Relubricate the sear and hammer notch surfaces and the hammer/disconnector engagement surfaces with sear lube. Do not use gun oil, as it is not adequate for the high-load applications of the sear and hammer surfaces.
8. Place a drop of gun oil on the trigger and hammer pivot pins. Do likewise for the takedown and pivot pins in the receiver.
9. Place a 1/16" hex driver on both sides of the JP Anti-Walk Pins and attempt to turn counter clockwise to verify that the screws are still properly secured. If either side backs out with little or no force applied, remove the screws and thoroughly degrease the threaded hole

and the screw using a solvent such as lacquer thinner. Apply an appropriate thread locker product (such as Loctite® 242) and allow it to cure as instructed by the manufacturer before further use. Check the screws again after the thread locker sets up.

10. Finish reassembling the rifle as described in the reassembly instructions.

Inspection of Critical Parts

During or after every cleaning, certain components and surfaces of the bolt/carrier assembly should be inspected for wear or damage. Parts exhibiting the following conditions should be replaced:

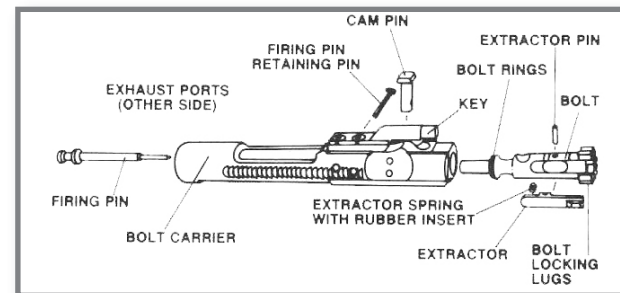

- **Bolt assembly:** cracks around the cam pin hole and locking lugs, excessive pitting of the bolt face, pitting extending to the firing pin hole (While some gas erosion is acceptable, excessive erosion in this area is an indication of firing overpressure rounds or reloading brass that is no longer serviceable.)
- **Ejector pin in the bolt face:** sloppy movement, poor spring tension (Test this by pushing and releasing the pin to gauge its movement.)
- **Firing pin:** blunt or fractured tip, bent shaft or cracked anvil end
- **Firing pin retaining pin:** bent or broken legs, general bad wear
- **Cam pin:** cracks, excessive wear or chipping
- **Extractor:** chipping, broken edges on the hook that engages the cartridge rim

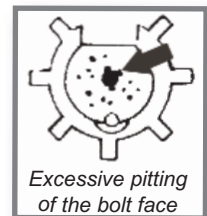

Replacement of Parts

Over the life of your rifle, you should expect to replace certain parts with varying frequency. The extractor, extractor spring, gas rings on the bolt assembly and ejector spring, should be replaced every 2,000 to 5,000 rounds. A Mil-spec bolt assembly should be replaced every 6,000 to 8,000 rounds. Gas tubes should be replaced every 4,000 to 5,000 rounds. Compensators may last 8,000 to 12,000 rounds. Barrel life is a matter of personal need and the quality of maintenance and ammunition. If you need the maximum potential accuracy, typical barrel life expectancy is considered 3,000 to 6,000 rounds. However, we have many users who have over 20,000 rounds through JP Supermatch™ cryogenically treated barrels and are still achieving sub-MOA accuracy. A rifle that still shoots into ¼ MOA is very accurate in terms of field use, and there is no need to replace a barrel until it literally no longer provides a level of accuracy required for your application.

Barrel replacement should only be performed by JP Enterprises, Inc. if you expect original equipment performance. However, in most cases, by the time you have worn out a barrel, you really need a complete new upper assembly. Replacing a barrel is usually not cost effective.

Unlike a bolt-action rifle, which many view as a lifetime purchase, a self-loading rifle is usually subjected to much more use and certain parts must be viewed as consumable and so should be replaced as part of a long-term maintenance program to prevent the eventual failure of these components as they exceed their service life.

It is advisable to have certain parts on hand as spares when shooting your rifle. With a simple parts kit, the vast majority of problems due to parts failures can be solved in minutes. A kit should include a set of gas rings, extractor/spring set or a complete bolt assembly, firing pin, cam pin and firing pin retainer pin. You may also want to have a complete bolt/carrier assembly in reserve. For the sake of versatility, you may even decide to have both a JP Low Mass Operating System and a JP Tactical Operating System available, as they can be interchanged in a matter of minutes.

Cleaning the Crown

On barrels equipped with muzzle brakes, there is a condition we refer to as the “false crown,” which needs to be addressed occasionally. As the rifle is fired, the carbon and vaporized jacket material forms a coating on the actual crown of the barrel. As long as this “false crown” remains uniform in shape and geometry, the barrel will continue to shoot accurately. At some point, this buildup will become too thick, and a chip will detach next to the bore. This will cause reduced accuracy identical to that caused by a flaw or defect in the actual crown. When this happens, the brake must be removed and the crown thoroughly cleaned. Until this becomes necessary, we do not recommend removing the brake unnecessarily as it may be damaged if done improperly, and the precise timing and seamless blend of the brake with the barrel will eventually be lost.

Cleaning the crown is usually required every 2,000 to 3,000 rounds depending on the fouling characteristics of your particular ammunition. We recommend sending the upper assembly to us

for our Upper Assembly Service Package, which includes a complete cleaning of the upper assembly components, replacement of gas rings, cam pin and firing pin retainer pin, removal of the brake, cleaning of the crown, recutting of the crown if necessary and inspection of the bore with a bore scope. Reference our website or call us for shipping instructions and pricing.

If you decide to attempt this procedure yourself, the muzzle brake must be removed from the barrel. Assuming it is not pinned and welded, it is threaded and removable. However, Loctite® 242 is used to secure the brake at the time of installation. To begin, lock the upper receiver in a padded vice. Do not use too much force as you may crush the receiver. You must heat the attachment area of the brake with a propane torch to soften the Loctite®. Never use a wrench of any type on the brake or barrel, as this will cause irreparable damage to the surfaces of those parts. Use a hard wood dowel—rather than a metal rod—through the expansion chamber of the brake to apply enough torque to remove it. The brake will unscrew by rotating counter-clockwise looking at the muzzle.

Once removed, you will have access to the crown of the barrel. In some cases, the false crown actually comes off with the brake and appears like a washer with a hole in it in the threaded area of the brake. In other cases, the buildup will remain on the surface of the crown, and it must be removed with care. First, let the crown soak in a bore solvent bath for a few hours. This may loosen the material so it chips off with a piece of hard plastic like the end of your cleaning brush. Work from the outside towards the bore, but do not touch the actual edge of the crown and bore with any metal object that could put a nick in the crown. If this happens, the crown must be recut.

After the buildup has been removed, polish the crown gently with a piece of Scotch-Brite® by holding the material on the crown and turning the barrel into it. Inspect the crown for any damage at this time before remounting the brake. Again, clean and degrease the threads and coat with Loctite® 242 to prevent the brake from vibrating loose under live fire.

Cleaning the Magazine

It is advisable to also clean the magazine(s) whenever the firearm is cleaned. To do so, make sure that the magazine is empty and remove the bottom plate by pressing in on the spring catch located beneath the small round hole, and sliding the plate off the magazine while controlling the magazine spring. Remove the spring and magazine follower. This may seem difficult at first, but it can be accomplished without the use of extreme force. Clean all the internal components and wipe the spring with a light coat of oil. Leave all other components dry and reassemble the magazine in reverse order. Use powdered graphite to lubricate the magazine after it is loaded. Never use oil on the magazine body or follower.

Special Cleaning Considerations

Beyond regular maintenance, you should be aware of certain conditions that will necessitate immediate or specific cleaning procedures. Before firing your rifle, you should check the barrel and chamber to ensure that they are clean and dry. After firing, expect to disassemble and clean the rifle within a 24-hour period to make the job easier and to allow less time for any corrosion to

start. Check it again within a few days to ensure that no further cleaning is necessary. If your firearm has not been used for some time, you should perform a routine cleaning at least once or twice a year in a temperate climate. If you carry a loaded firearm, unload it and clean it when necessary or at least once a month. If you get your firearm wet, clean it as soon as possible. Below is a listing of environmental factors and how they should affect your firearm maintenance routine.

Extreme Cold

- Clean and lubricate your rifle with a degreasing agent and keep it free from moisture like condensation. In freezing conditions, apply a dry lubricant sparingly in place of oil. We recommend powdered graphite like a locksmith would use. Most oils will harden and cause excessive hydraulic friction and subsequent malfunction on self-loading rifles.
- At intervals, operate the rifle's controls through their entire range to keep them from freezing up.
- If your rifle is being kept outside unused, protect it with a cover. If you are using the rifle in extreme cold conditions, it is wise not to bring it into a warm humid situation like a cabin, but rather leave it cased or racked in the cold.

Hot, Humid Climates

- Inspect the rifle and any bipod you may use more frequently, especially the hidden surfaces of the bolt carrier group, forward assist assembly (if applicable) and lower receiver components. Make sure they are lubricated with gun oil. Use a good gun oil or rust preventative on any carbon steel components to prevent corrosion.
- When handling, make sure to wipe dry, as moisture can cause corrosion. After drying, lubricate with gun oil.
- Because of the adverse effects of humidity, be prepared to perform routine cleaning as often as every week. In particular, salt spray environments may require daily service even on stainless components.

Hot, Dry Climates

- Perform regular cleaning more often and make generous use of gun lubricant when oiling the rifle.

Dusty or Sandy Environments

- Clean and generously lubricate the rifle more frequently.
- Keep sand away from the rifle's interior parts when inspecting, lubricating or assembling the rifle. Apply only a light amount of lubrication on the outside of the rifle.
- Use a magazine bag and muzzle cap for dust and sand protection.

Storage

Store your firearm and ammunition separately in a securely locked location out of the reach of children and other unauthorized users. Do not store your firearm in an airtight container, and do not seal or attempt to seal the barrel to exclude dust, as the internal steel surface is more likely to corrode. If you intend to store the firearm long term, purchase a sealing anti-corrosion bag designed for that purpose. When taking the firearm out of storage, be sure to run a clean swab through the barrel to remove any oil film before use.

TROUBLESHOOTING

This section is intended to address some of the most common problems encountered by the operators of self-loading rifles. Many of the problems are easily remedied with a combination of patience, minor adjustment and observation. If you would prefer to have JP Enterprises, Inc. or a qualified gunsmith inspect your rifle, make sure to carefully note all details regarding the malfunction as well as the positions of the cartridges and mechanisms involved.

The rifle fails to fire when the trigger is pulled...

Hangfire

If, while operating your rifle, you depress the trigger and hear the hammer fall, but the weapon does not discharge, keep the muzzle pointed towards a safe backstop for 30 seconds. If a hangfire (slow ignition) has occurred, the weapon will discharge in that time. If it does not discharge, remove the magazine, lock the bolt back, clear the chamber and examine the primer of the faulty round. If the indent from the firing pin is light, off-center or non-existent, have your firearm examined by a qualified gunsmith. If the indent seems consistent with previously fired rounds, assume that the cartridge was faulty and segregate it from other ammunition and shells. Dispose of misfired cartridges as instructed by the manufacturer. If you extract a cartridge with no bullet, you may have a projectile lodged in the bore. Refer to the "Projectile Lodged in Bore" section below.

Failure to Go into Battery

If you have depressed the trigger, heard the hammer fall but the rifle has failed to fire, the action of your rifle may have failed to go into battery, meaning the action is not in the closed and locked position. If you observe that the bolt carrier is not all the way forward, do not attempt to force it closed. The SCR-11, CTR-02 and LRP-07 do not have a forward assist for that reason, and this feature is not required on a civilian recreational rifle. The PSC-15 and JP-15 series do have the forward assist, but it should not be used to resolve a failure to go into battery. Doing so will only lock a live round in the rifle, which will need to be disassembled to solve the problem and remove the chambered round.

If your rifle does not go into battery, it may have debris or some other obstruction in the chamber. However, the most common cause of this problem is out-of-spec ammunition, which means the cartridge does not fit the chamber for some reason. If you are reloading or have purchased reloaded ammunition, the sizing die may not be properly set. Verify the sizing of your ammunition before continuing to use it. Such reloading problems are covered in detail in the *GasGunBasics™* DVD.

Failure to Reset

If you depress the trigger and the rifle does not fire, but you did not hear the hammer fall, unload the rifle by removing the magazine and clearing the chamber. Try dry-firing the rifle by cycling it and pressing the trigger. If the hammer does not fall and the trigger does not follow its usual front-to-back movement, the fire control system may be failing to reset. In other words, the hammer is not releasing from the disconnecter to reset back to the sear face. This is typically caused by dirt or debris such as a brass shaving, unburned powder or a grain of sand lodged under one or both of the trigger adjustment set screws. This will prevent the trigger from returning all the way forward, which is necessary for the hammer to be released by the disconnecter to reset the mechanism. If this is the case, the fire control cavity of the lower assembly should be properly cleaned. If this fails to solve the problem, contact JP Enterprises, Inc. for service.

Projectile Lodged in Bore

If a popping sound is audible while firing the rifle instead of a full report or you experience reduced recoil, remove the magazine, lock the bolt back, clear the chamber and switch the safety selector lever to "SAFE." Visually check or insert a cleaning rod into the bore to determine if a round or some jacket material is lodged inside. If so, cease all use of the rifle and contact JP Enterprises, Inc. or a qualified gunsmith. Firing another round behind a projectile lodged in the barrel will destroy the barrel and may cause serious injury to shooters and bystanders.

The rifle fires multiple rounds with one pull of the trigger...

Fire on Release

A worn disconnecter or sear surface is allowing the hammer to follow the bolt forward so that it is not retained by the disconnecter, which causes the rifle to fire when the trigger is released. In other words, the rifle will fire when the trigger is pressed and again when the trigger is released to the reset position. The problem will eventually appear in all M15-type rifles as parts wear if the fire control mechanism is not properly serviced and inspected. Performing the disconnecter test as laid out in the trigger section of the *GasGunBasics™* DVD will give you advanced warning when parts may need to be replaced to prevent this problem from occurring. If don't feel capable of making this judgment, have a competent gunsmith check your trigger mechanism. This test should be performed during every service so you are aware of the fire control system's condition and any changes that occur.

Slam Fire

It is well known that M15-type rifles may exhibit a slam fire in which the weapon fires when the bolt closes during loading or during live fire. This is a design issue, and through firing pin modifications and ammunition development has been nearly eliminated over the years. However, it is always a possibility and must be anticipated. Therefore, when loading the rifle by dropping the bolt on a loaded magazine, have the muzzle pointed in a safe direction.

A slam fire can result from firing pin inertia exerted on the action closing. The bolt and carrier assembly are propelled forward by the buffer spring with considerable velocity that is imparted to the firing pin, which then taps the primer as the bolt turns closed into battery. You will notice that when unloading the rifle, the last round will always have a dimple from the firing pin hitting it as the bolt comes into battery on the round fed after the last shot fired. This is normal and not a problem with properly loaded ammunition.

Another cause of slam fire is the firing pin being locked into the forward position due to a bent firing pin retainer pin or excessive lubrication or debris lodged in the firing pin channel. If the firing pin does not float freely in the firing pin channel of the bolt assembly, it may not bounce back when hitting the primer on close and cause a slam fire situation.

Finally, slam fires may result from primers that are too sensitive for the application. For this reason, some so-called rifle primers are not suitable for use in self-loading rifles.

The solution for a reoccurring slam fire condition is to change to a titanium firing pin. The titanium firing pin has very low mass and therefore will retain very low inertia on close.

Finger Bounce

Another common cause of what is commonly referred to as "doubling" is the finger bounce effect. Failure to use proper trigger control techniques—as demonstrated in the *GasGunBasics™* DVD—may result in the trigger finger bouncing on the trigger due to the recoil impulse of the rifle, which causes the rifle to fire multiple times without the shooter being in control. Proper trigger control technique is essential for the safe operation of your rifle and is unlike such techniques used on manually operated rifles.

The rifle suffers from stoppages or jams...

It is important to note that this section refers to reoccurring stoppages, rather than one malfunction in hundreds or thousands of rounds. No mechanical device functions perfectly at all times, and every self-loading rifle, pistol or shotgun will malfunction at some time, despite claims about some firearm that has never done so. As with anything, it is important to have realistic expectations.

There are many types of stoppages, and not all of them can be covered here. A self-loading rifle functions as a materials handling system. Some material (ammunition) is delivered through a feeding device (the magazine), is processed (fired), and the remains are discarded (spent case

extracted and ejected). Like every mechanical device, it has an “operational window.” It is important to know that any malfunction scenario is usually the result of several factors combining to collapse this operational window until finally a stoppage occurs. Stoppages and malfunctions are rarely the result of one factor, and correcting any one of the contributing issues may bring the system back into its operational window. The best diagnostics and remedial approaches will cure most or all of the issues that contribute to a particular malfunction and thereby expand the operational window as much as possible. The larger the operational window, the greater the range of physical conditions under which the rifle will continue to function.

In the realm of high-performance firearms, we are willing to make some compromises on the size of the operational window in return for some significant improvement in performance. For example, the JP Low Mass Operating System delivers a significantly improved sight recovery time, reduced recoil impulse and smoother overall feel to the cycling of the rifle at the cost of a slightly reduced operational window. Some applications, such as military or law enforcement use, do not allow for this compromise, and should instead use JP Tactical Operating System, which does not constrict the operational window as much. Some users will also decide to have both operating systems, as they can be interchanged in a matter of minutes.

This section covers the most common stoppages, addressing the causes and solutions to each. It is important to be very observant when trying to diagnose a problem or relay it to someone for technical support. If your rifle leaves a spent case in the chamber, for instance, this is known as a failure to extract. If it leaves the spent case in the ejection port, this is a failure to eject. It is important to know which problem your rifle is experiencing.

Failure to Extract

Failure to extract is usually caused by excessive chamber pressure and or port pressure of a particular load but can be caused by inadequate extractor tension or a defective extractor. First, change ammunition or reduce your load density, and then try reducing the pressure of your gas system. If this does not remedy the problem, you may need to replace the extractor components or the complete bolt assembly.

An extraction failure can also be the result of a pit or flaw in the chamber caused by corrosion or a piece of debris embedded in the chamber wall. For this reason, a clean, well-finished chamber is essential to reliable extraction. A chamber that is pitted or corroded may require the replacement of the barrel. Grit or brass shavings falling into your loaded magazine and sticking to the outside of the cases can also cause extraction failures and even damage to your chamber. Never use a loaded magazine that has fallen into the dirt. It must be stripped and cleaned before the ammunition is fired.

Failure to Eject

The spent case was extracted successfully, but did not make it out of the upper receiver to be ejected. This can be caused by a sticky ejector pin in the bolt face, which is often the result of a brass shaving lodged between the ejector pin and the hole in the bolt face.

Brass shavings embedded in the ejector pin hole are an indication of overpressure ammunition. An overpressure round will extrude the case head into the ejector pin hole and firing pin hole. When the bolt unlocks, this extruded material will be shaved off the back of the case and foul the ejector pin, firing pin channel and even fall into the magazine or fire control cavity creating other problems in addition to ejection failures.

Another common cause of a failure to eject is a round with low port pressure, which causes the operating system to “short stroke,” meaning it does not travel rearward sufficiently to allow the cartridge to clear the port. If you are using ammo that has been reliable, and this stoppage is now occurring consistently, the first thing to check is the ejector pin in the bolt face. If you have changed ammo, you probably have a port pressure issue. Try loading and firing one round in your magazine. If the bolt has not locked back, your port pressure is too low. You may want to change ammo or adjust the gas system on your rifle to allow more pressure into the operating system if you intend to shoot more of that ammunition. If the port pressure is too low to function with the gas system fully open, you must change your load. Refer to the **JP Adjustable Gas System** section above.

If you load and fire one round in a magazine and the bolt does lock back and the case fails to eject, your rifle may be over-gassed, which causes the operating system to cycle so fast that the spent case doesn't have enough time to clear the ejection port. In this case, adjusting the gas system to lower the pressure delivered to the operating system may solve the problem, as will changing your ammunition or load.

Failure to Feed

A failure to feed can take several forms, each of which is caused by unique factors. The most basic failure to feed involves the rifle firing, ejecting the spent casing, and closing on either an empty chamber or on a cartridge that is only partially stripped from the magazine resulting in a “bolt ride-over.” One cause of this problem is a weak magazine spring or a magazine that is otherwise defective. The magazine may also be dirty or not properly prepped with graphite. Alternately, the ammunition port pressure may be excessive, causing the operating system velocity to exceed the magazine's feed rate.

The rifle may also fail to feed because a loose round in the upper receiver is jammed in front of the bolt, or there may be a combination of a loose round and the bolt attempting to feed a second round for a double feed. This again is usually indicative of a defective magazine, which should be replaced.

If a round stops on the feed ramp of the barrel extension—in some cases actually collapsing the bullet into the case—this can be caused by using inappropriate or oddly shaped projectiles, such as jacketed hollow points with overly large hollow points. Out-of-spec cartridge lengths and projectile shapes are not suitable for use in a self-loading rifle and will tend to cause such errors.



**CTR-02 in Custom
Pelican Case**

JP Enterprises, Inc.

***P.O. Box 378
Hugo, MN 55038***

***Voice: 651-426-9196
Fax: 651-426-2472***

www.jp Rifles.com