



PARTS INCLUDED

- | | |
|--|---|
| • Trigger module | • Two (2) JP Anti-Walk Pins |
| • Safety selector drum | • Four (4) 4-40 button head cap screws |
| • Full-profile safety lever | • Yellow hammer spring (alternate rate) |
| • Low-profile safety lever | • Two (2) T8 hex keys |
| • Two (2) 8-32 x 3/8" flat head cap screws | • One (1) 1/16" hex key |

CAUTION: REMOVE MAGAZINE AND VISUALLY CHECK CHAMBER TO MAKE SURE THAT FIREARM IS UNLOADED.

The JPFC-M module is a drop-in fire control solution that brings convenience to the unmatched quality of a JP trigger. Be aware that this installation will require use of a padded vise and certain other tools not included in this kit, including:

- Mallet and drift pin
- Loctite® 263 (red) or equivalent thread locker
- Gun grease
- Loctite® 242 (blue) or equivalent thread locker

This version of the JPFC-M includes a changeable trigger shoe feature. Instructions for changing out the shoe are included here. An alternative rate hammer spring is also included in this package. Instructions for changing this out are also included.

The JPFC-M is not intended for installation in polymer receivers.

PRE-INSTALLATION

1. Remove the magazine from the rifle and verify that the chamber is clear.
2. Separate the upper and lower receiver assemblies. Push out the rear takedown pin and pivot the upper assembly down and away from the lower assembly. Then, press out the front pivot pin and separate the assemblies.
3. Secure the lower assembly in a padded vise. You will need access to the fire control cavity, the trigger and hammer pin holes and the grip/trigger/safety area. Clamp the receiver tightly enough to secure but not over-tight such that the receiver shape is distorted.

4. Remove the existing fire control components. Using a plastic mallet and drift pin, carefully tap the existing trigger pins out of the lower receiver. First, remove the hammer pin and hammer followed by the trigger pin, trigger and disconnecter.
5. Remove the existing safety selector. Loosening the grip screw so that the pistol grip can be pulled away slightly from the receiver without being removed. This will relieve tension on the safety detent plunger, which will allow you to remove the existing selector from the receiver. Take care not to lose the safety detent and spring.
6. Clean out the fire control cavity as needed. Remove any debris or dirt in the bottom of the fire control cavity that could interfere with the fire control mechanism.

INSTALLATION

1. Turn the 6-32 tensioning set screws in the housing clockwise until they protrude from the bottom of the housing at least 1/8".
2. Apply a small amount of Loctite® 263 to each tensioning screw. Then, turn them back in so they are flush with the bottom of the housing. **Tensioning these screws is critical for safe, reliable function.**
3. Cock the hammer and insert the module into the receiver's fire control pocket.

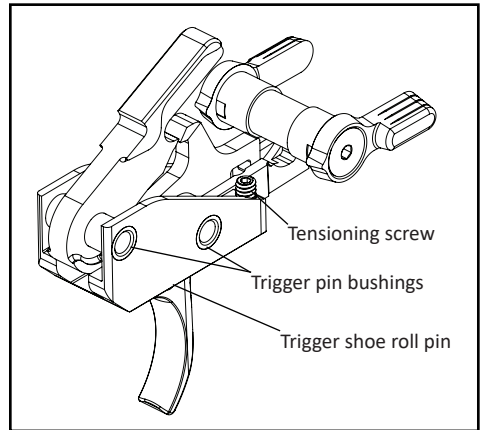

4. Apply a small amount of Loctite® 242 to the supplied 3/8" flat head cap screw. Use this to attach one safety lever to the safety drum as shown below. Choose the lever you'd prefer for the left side of the receiver—typically the full-profile lever for right-handed shooters, low-profile for left-handed shooters.

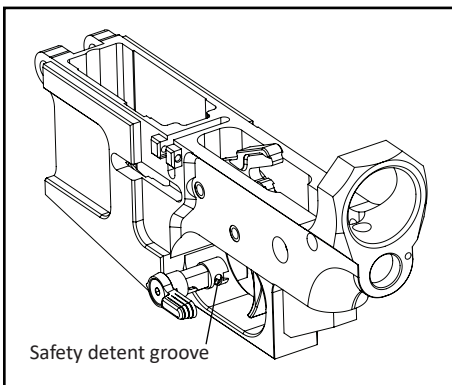

5. Apply a small amount of grease to the safety detent groove of the safety, and install the safety from the left side of the receiver so that the groove aligns with the safety detent hole in the lower. You may have to tilt the trigger module in order to slide the safety through.
6. Keeping the safety drum centered in the lower, install the JP Anti-Walk Pins through the lower and trigger module. Insert the four button head cap screws to secure the pins and tighten these using the two supplied keys.

7. Center the housing within the fire control pocket and tighten down the tensioning screws at the back of the module. Tighten slightly on alternate sides to evenly distribute pressure. Do not tighten more than 8 in-lbs. as this could damage the receiver or screws. Allow the thread locker to cure for 24 hours prior to use.
8. Keeping the safety selector in place, re-secure the grip while making sure the safety detent and spring engage with the safety detent groove in the safety drum.
9. Verify function of the safety:
 - With the hammer still in the cocked position, verify that the safety turns freely with a pronounced click at the SAFE and FIRE positions.
 - With the safety in the SAFE position, make sure there is little to no movement of the trigger and that the hammer cannot drop.
 - With the safety in the FIRE position, the trigger should release the hammer with little or no perceptible creep. Do not pull the trigger without controlling the fall or without a JP Hammer Stop Block (JPFC-HS) installed as this could damage your lower receiver.
10. Verify function of the trigger. With the trigger pulled to the rear, manually cock the hammer. The hammer should snap over the disconnecter hook and be held in place until the trigger is released. Verify that the disconnecter releases the hammer and that the hammer catches on the trigger sear when the trigger is released.
11. Install the second safety lever on the right side of the receiver as you did the first.

If you encounter any issues while installing your JP trigger module or cannot verify safe, reliable function, do not use your rifle. Contact JP technical support for assistance.

SWAPPING TRIGGER SHOES

1. Remove the JPFC-M from the lower receiver.
2. Use a 1/16" punch to drive out the roll pin securing the trigger shoe in place. This pin can be located at the top of the trigger shoe, just below the housing.
3. Slide the current trigger shoe forward and off the trigger body. You may need to rock the trigger body forward to create enough clearance. If so, ensure that the hammer is not cocked and push up on the rear of the trigger body to rock it forward.
4. Slide the new trigger shoe on from the front of the trigger body. If you meet resistance, clean the contact areas of any debris and try again.
5. Line up the hole in the trigger shoe with the half-moon slot in the trigger body. Drive in the supplied roll pin. The roll pin should be just flush on both sides of the shoe.
6. Reinstall the JPFC-M module as described above.

SWAPPING HAMMER SPRINGS

The pre-installed hammer spring in the JPFC-M is our red, increased reliability spring. It is intended for large-frame (AR-10-type) rifles, rimfire applications or for use of NATO or Mil-spec primers in your small-frame rifle. If none of these applies to your setup, this spring can be changed out for the included yellow competition hammer spring, which provides excellent reliability with most types of brass-case ammunition with a 3-3.5lb. pull weight.

1. Remove the JPFC-M from the lower receiver.
2. Release tension on the hammer sear by pulling the trigger, making sure to retain control of the unit while doing so.
3. Drive out the bushing the holds the hammer and hammer spring in place. Use a tool that is less than .250 in diameter. This should not require excessive force if the parts are aligned. You may have to wiggle the hammer to fully push or pull the bushing through to the opposite side.
4. Remove the existing hammer spring and then wrap the new spring around the hammer in like fashion.
5. Pinch the hammer spring so that you can slide the parts back into the housing from the top. The legs of the hammer spring should rest outside the trigger return spring.
6. Slide the hammer bushing in place until it is flush with both sides of the housing.
7. Reinstall the JPFC-M module as described above.

THANKS FOR YOUR BUSINESS!